

28"x28" Centerpiece



Templates and Tools

- Leaflets 1 & Leaflets 2 Templates
- OPTIONAL: Basic Marker, 4"x12" or 12"x12"

28" x 28" FINISHED SIZE

Prepare:

- Cut 1@ 30" x 30" (front fabric)
- Cut 1@ 30" x 30" (backing fabric & batting)
- Cut 3 strips @ 2.5" x WOF (binding)

Layer quilt sandwich with batting between layers.  
Quilt according to instructions.  
Trim to 28" x 28" and attach binding.

**LEAFLETS**

(2 Templates, 4 Sizes)

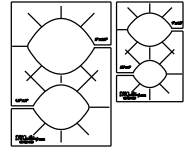

**DROPLETS**

(3 Templates, 5 Sizes)

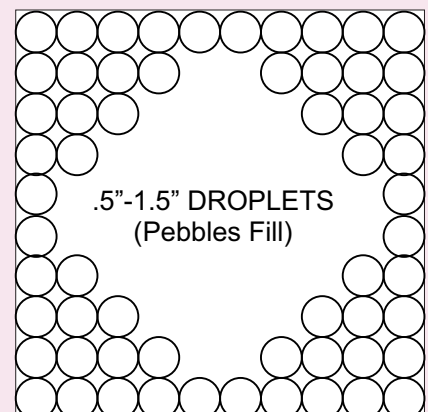
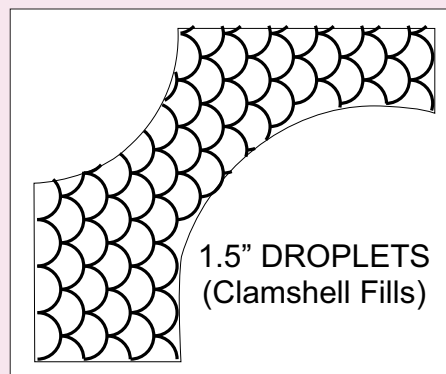
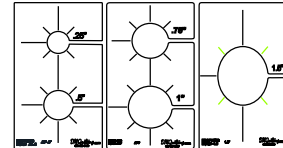

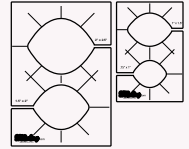

**LEAFLETS**  
(2 Templates, 4 Sizes)

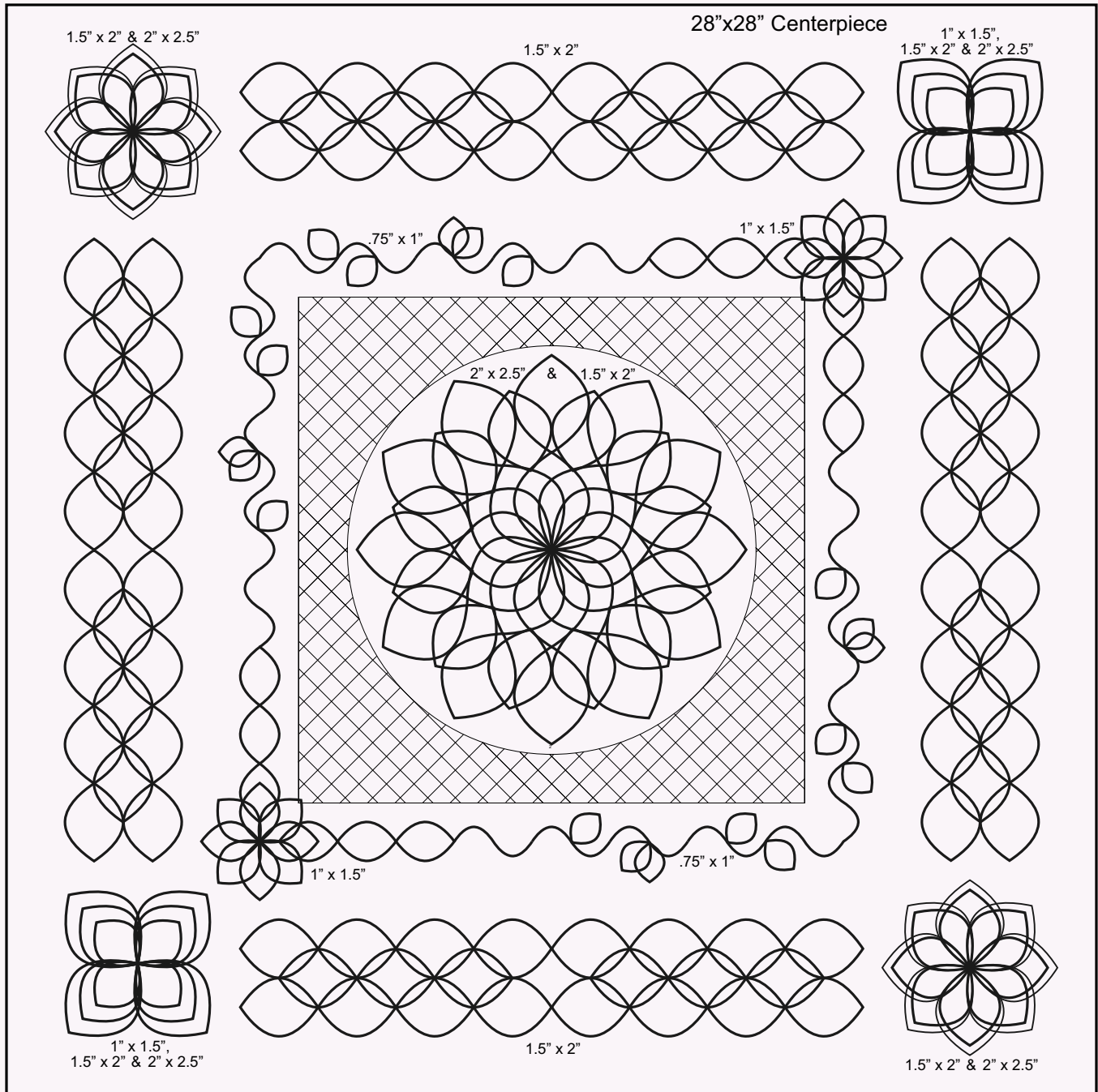

**Templates and Tools**

- Leaflets 1 & Leaflets 2 Templates
- OPTIONAL: Basic Marker, 4"x12" or 12"x12"

**28" x 28" FINISHED SIZE**

Prepare:

- Cut 1 @ 30" x 30" (front fabric)
- Cut 1 @ 30" x 30" (backing fabric & batting)
- Cut 3 strips @ 2.5" x WOF (binding)

Layer quilt sandwich with batting between layers.  
Quilt according to instructions.  
Trim to 28" x 28" and attach binding.

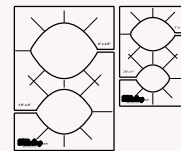

**LEAFLETS**  
Project Instructions

**PREPARE FABRIC:**

- Cut 1 each @ 30" x 30" - for the front fabric, backing & batting
- Cut 3 strips @ 2.5" x WOF for binding
- Layer all 3 together creating a quilt sandwich with batting in the middle.

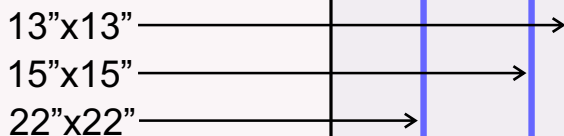

Mark foundation centering lines spacing them as shown in diagram. Additional marking will occur at each STEP where needed.

*When all quilting is complete, trim to 28" x 28" and attach binding.*

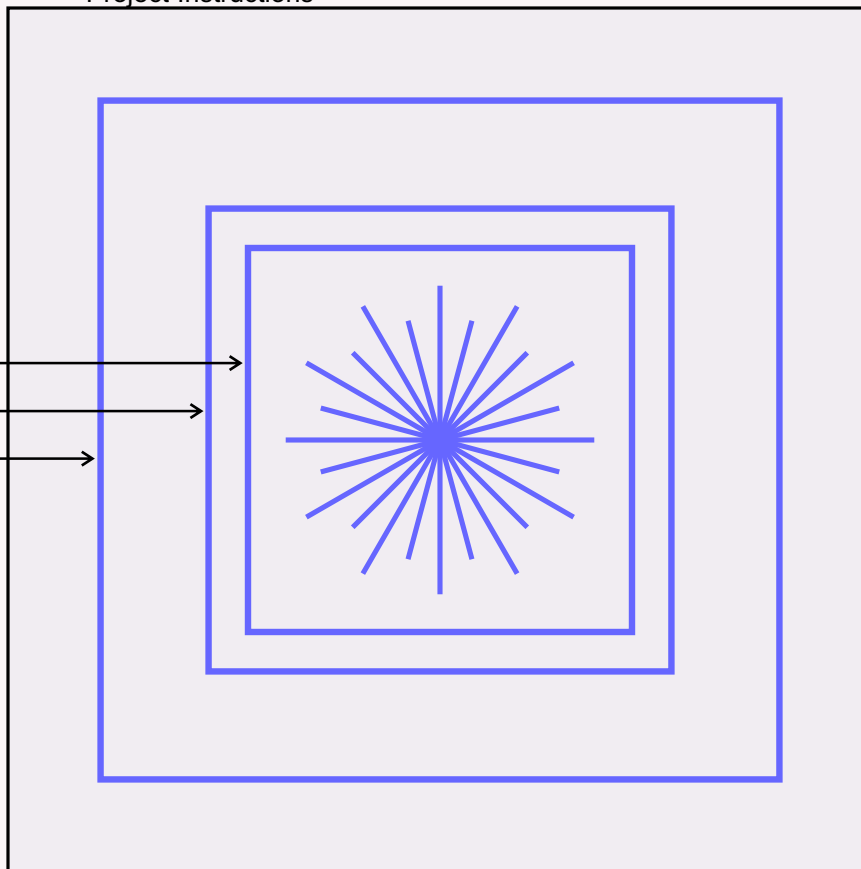

**Begin with 30" x 30"**  
**Final Finished Size 28" x 28"**

Understanding  
Template Markings

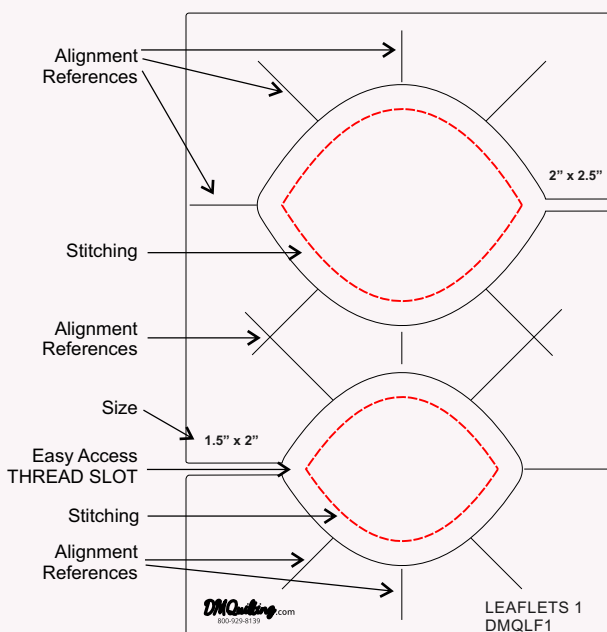

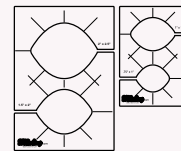

## GENERAL OVERVIEW

Part 1

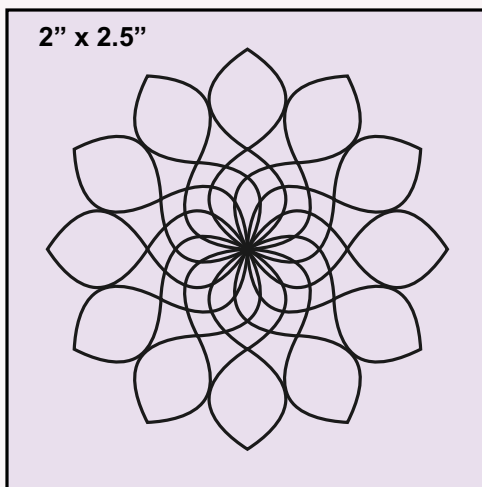

Part 2

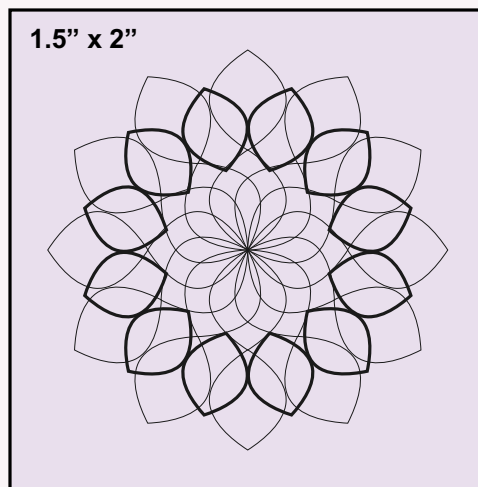

The Centerpiece center design element is stitched in two parts.

For Part 1, stitching will begin at the very center of the design using the largest size, **2"x2.5" LEAFLETS Template**. Twelve "double-sets" are stitched with the template pattern being stacked one on the other, per rotation, resulting in the double set.

Part 2 is stitched using the smaller size, **1.5"x2" LEAFLETS Template**.

*Detailed diagrams with template placement with stitch sequence details are on following pages beginning with STEP 1.*

### GETTING STARTED

With Foundation Lines marked, find the block center and lightly mark **24 Rotation lines** at the center using the **6-Point** marking square.

- The alignment marks should fill the space of approximately 11" in diameter.
- Mark 1 set of 12 longer marks, then rotate marking square and add a second set of 12 marks to fill a slightly smaller inside diameter of approximately 9-1/2". The second set should be positioned in between the first set of markings for a total of 24 marked lines. Refer to diagram.

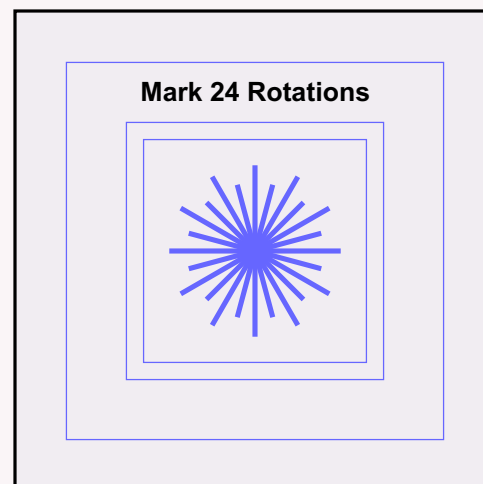





**LEAFLETS**  
Project Instructions

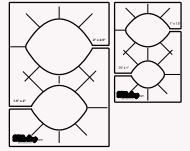

**STEP 2.**

- Align the optional Westalee Design 12" **ARC Template** as shown to stitch the circular pattern of the crosshatching grid.
- With needle inserted at **\***, stitch to the **X** and realign template for the next section.
- Repeat to complete the circle.
- When complete, stitch the border line of the 13"x13" outside grid.

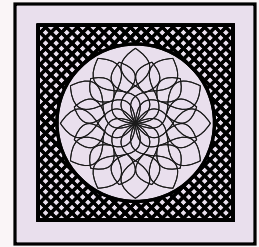

**Circular Grid Border**

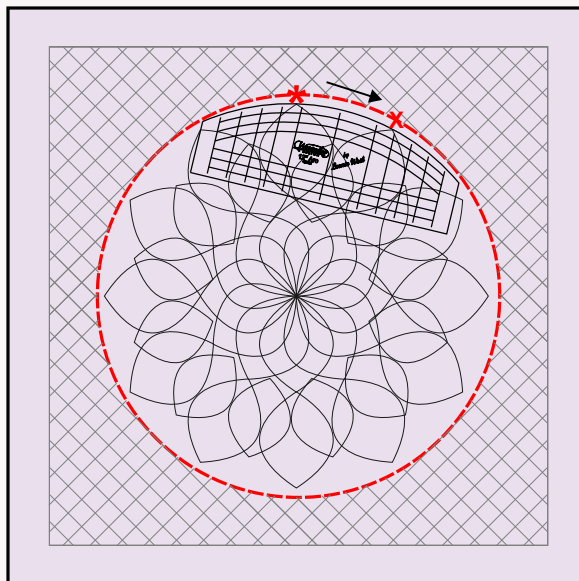

**13" Outside Grid Border**

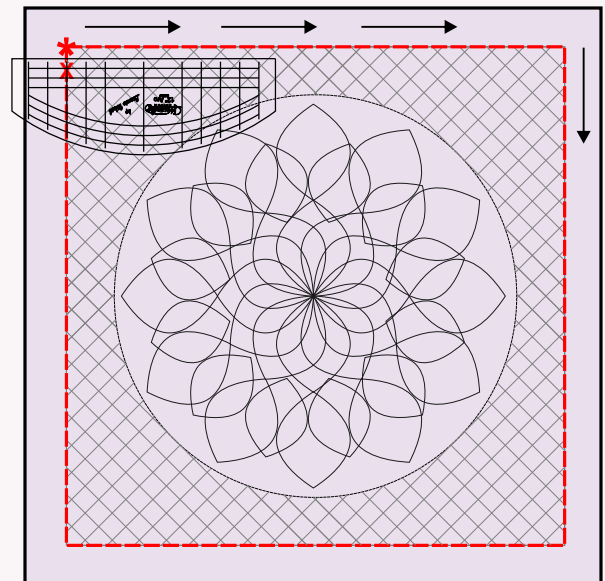

**1/2" Crosshatching**

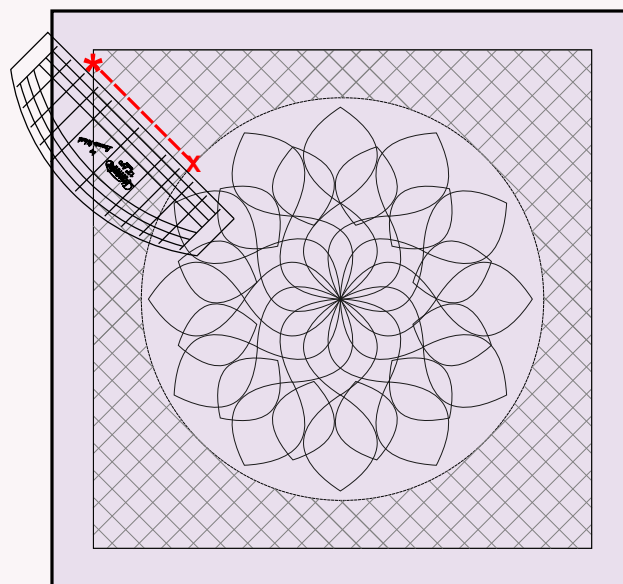

Using the **DMQuilting STRAIGHT AWAY** or the optional Westalee Design 12" ARC, begin near a corner and stitch crosshatching at 1/2" intervals. Work around between the grid border and circular edge as shown. Travel stitch where needed for next placement.

**LEAFLETS**  
Project Instructions

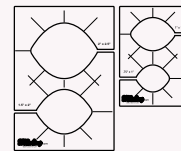

**STEP 3.**

- Mark the 15"x15" centering line. Choose two opposite corners and mark for 8 rotations approximately 4" in diameter in each of those two corners.
- Using the **1"x1.5"** **LEAFLETS Template** begin at the **RED \*** and stitch the entire pattern returning to center.
- Rotate template to next alignment mark and repeat.
- Stitch a total of 8 patterns in each of these two corners. Refer to images below.

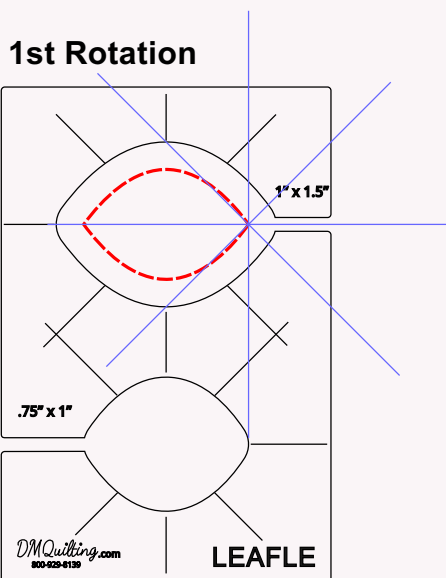
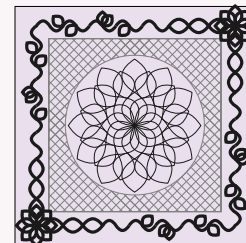

**Completed Corner Element**

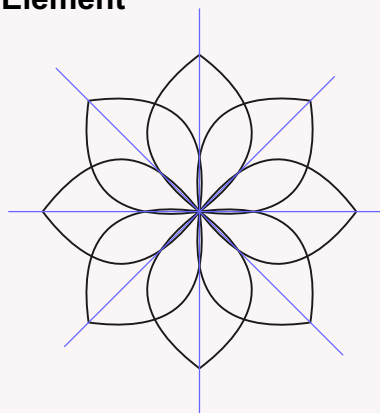

**STEP 4.**

- Move to a remaining corner of the 15"x15" centering line. Position needle exactly in the corner as shown in diagram **A**.
- Using the **.75"x1"** **LEAFLETS Template** begin at the **RED \*** and stitch a partial pattern only on the **RIGHT SIDE** of the template. Stop at the **X** with needle down.
- Slide template along the centering alignment line and stitch the **LEFT SIDE** of the template for the next partial pattern. Follow the diagram inserting a full pattern at the **LEAFLET** intersections as shown.
- Repeat for a total of 10 partial patterns to create the vine and leaflets.
- Proceed to diagram **B** and stitch 3 full patterns using the **1"x1.5"** **LEAFLETS Template**.
- Leave thread tails and return to starting location at the corner. Stitch reversing the right to left, etc., as you go to complete the vine along that side. Refer to diagrams.

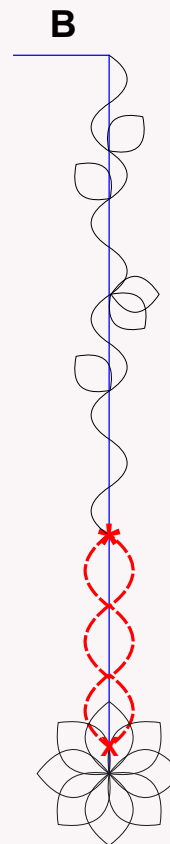
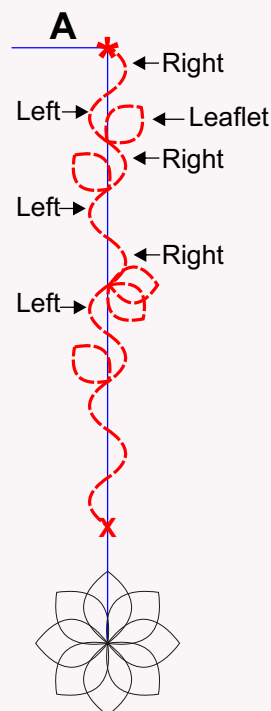

**LEAFLETS**  
Project Instructions

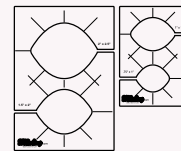

STEP 5.

- Mark the 22"x22" centering line for outside border element. Mark for 8 rotations in the locations as shown in diagram.
- **A.** Using the **1.5"x2"** **LEAFLETS Template**, begin at the **RED \*** and stitch the entire pattern returning to center for a total of 8 patterns.
- **B.** To create the echo effect, stitch outward to the **\*** as shown in diagram **B**. Position **2"x2.5"** **LEAFLETS Template** at the outside edge and stitch only to the point where the needle touches the previous stitch patterns stopping at **X**.
- Follow arrows to backtrack 1/4" and realign template for the next echo rotation.
- Leave thread tails and proceed to opposite corner to complete same design element of this outside border.

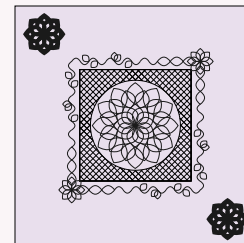

**A Corner Element without Echo**

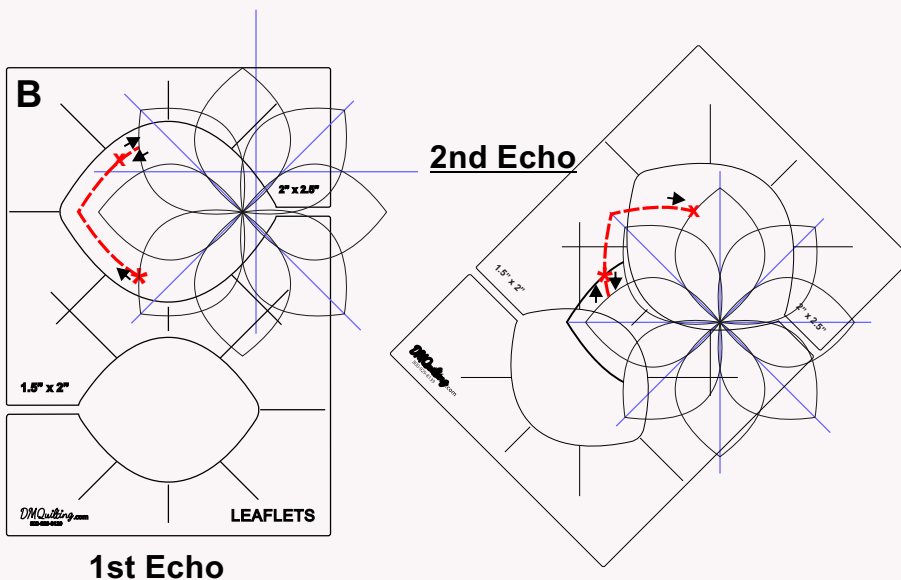
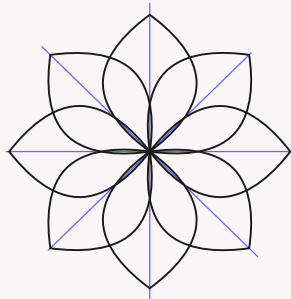

STEP 6.

The Stacked Design is created using three consecutive sizes of the LEAFLETS templates at the open corners of 22"x22" centering line for outside border element.

- Mark for 4 rotations in the directional orientation of your choosing.
- Using the **2"x2.5"** **LEAFLETS Template**, begin at the center of marks and stitch the entire pattern returning to center for a total of 4 patterns.

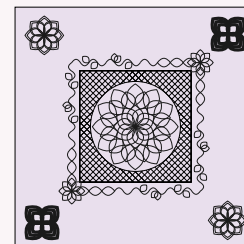

**Stacked Design Corner Element**

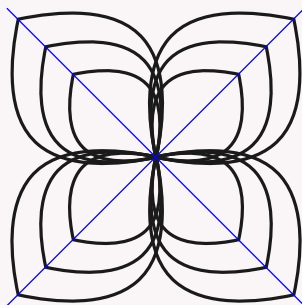

- Position the **1.5"x2"** **LEAFLETS Template** to stitch the same 4 rotation inside the first set of patterns. Remove template and position the next smaller size and repeat.
- Leave thread tails and proceed to opposite corner to complete same design element of this outside border.



**LEAFLETS**  
Project Instructions

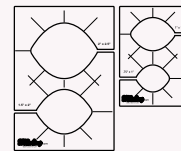

**STEP 7.**

Along one side of the 22" outside border, determine center location. Mark ends at 15" in length as row #1. Parallel to the line, mark 2 additional lines each being 3/4" away and 16" long and identify as row #2 and #3. See diagram below.

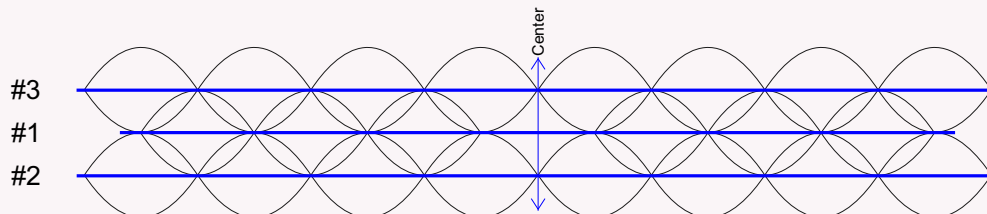
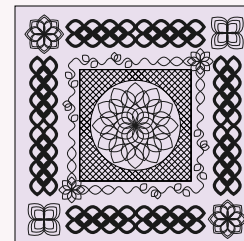

- **Row #1, Center.** Mark a 2" space at center. Stitching begins on each end of that space. Using the **1.5"x2" LEAFLETS Template**, begin at the **RED \*** near center mark and stitch 3 full patterns progressing toward the corner elements. Each pattern is stitched 1-1/2 times to end at opposite location from where starting.
- Return to center and repeat for the opposite side of Row 1 for a total of 6 patterns and a space in between. Stop with needle down at the **X**.

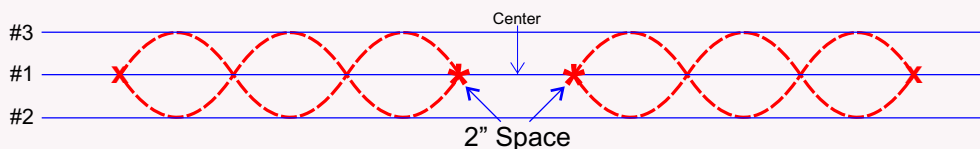

- **Row #2, Bottom,** continuing with the **1.5"x2" LEAFLETS Template** at the **\***, stitch 8 full patterns as shown stopping at the **X**.

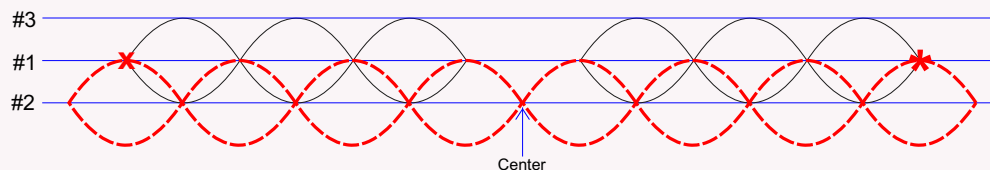

- **Row #3, Top,** reposition template to stitch the upper portion of the border rows returning to the opposite end. Leave thread tails and proceed to next side of border area.
- Repeat to complete same design element along each outside border line.

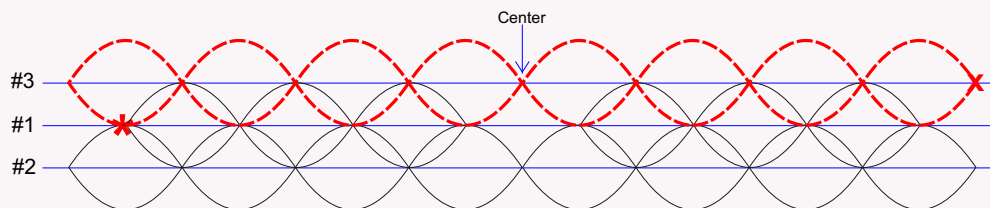

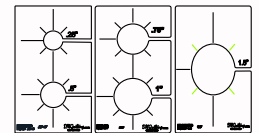

**DROPLETS**  
(3 Templates, 5 Sizes)

Ribbons & Bows Galore

**STEP 4.7 INSTRUCTIONS FOR BLOCK** as taken from Ribbons & Bows Galore

**About this Block ...** This overall or background fill design is created with the **1.5" DROPLETS TEMPLATE**. The **BASIC MARKER** is used to set the 3/4" grid line marks to help keep the Clam Shell background fill aligned.

**Tools and Templates Used**

- DMQuilting 1.5" DROPLETS
- DMQuilting BASIC MARKER 4"x12" or 12"x12"

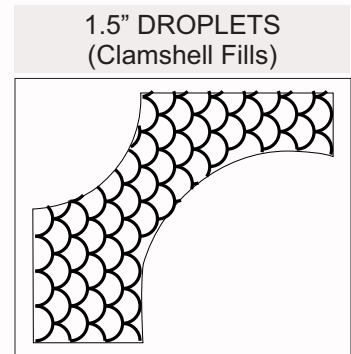
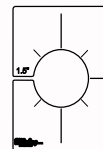
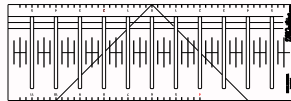

1. Position the **BASIC MARKER** at the lefthand edge of Block 7 so that marking will start 3/4" toward the right. See arrow below.

- With spaced dashes, mark at 3/4" intervals as shown.
- Slide the marking tool over to continue marking across the block as needed.
- Reposition and mark the entire block in this manner.

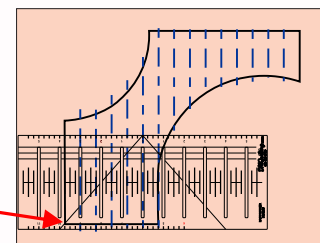

2. Position **1.5" DROPLETS Template** to begin stitching at the **RED \*** at the lower edge of Block 7. Place the template horizontal center line right on the edge of the block as shown 1st Shell diagram.

- Stitch only half of the DROPLET to create the shell in this design.
- Stop at the **X** with needle down and slide template to stitch the next half pattern. Repeat across the row.
- Begin even numbered rows by placing the vertical center of DROPLET at the center of the previously stitched row. Odd numbered row will be stitched the same as the first row.
- All shells are .75" high and 1.5" wide where space permits.

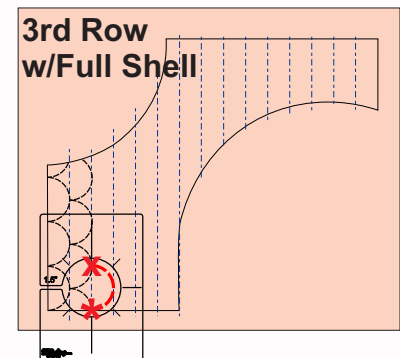
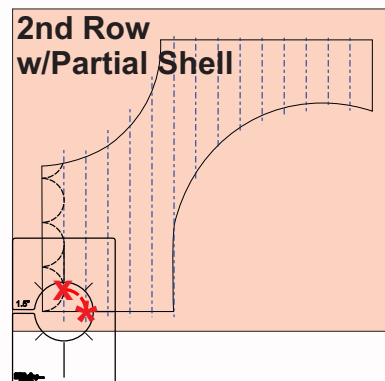
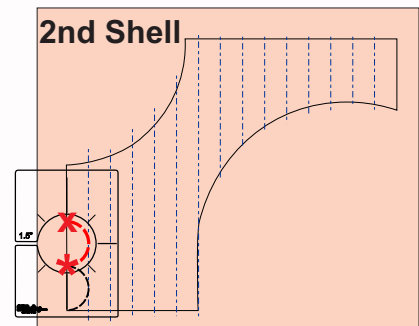
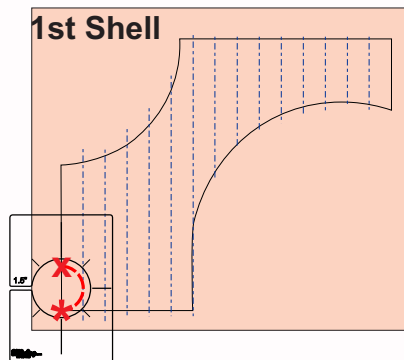

*TIP: For ease in stitching because of the circular row ends, it is acceptable to leave a thread tail at end of row and begin next row at the same edge where first row stitching was started. Move upwards vertically as the rows develop. Stop each row without stitching into the circles.*

Proceed with stitching all rows to fill the space of Block 7 with Clamshell Fills.

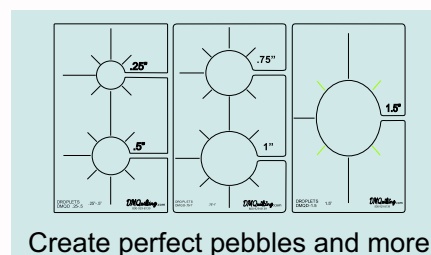

Create perfect pebbles and more!