

St. Patrick's Day Table Runner

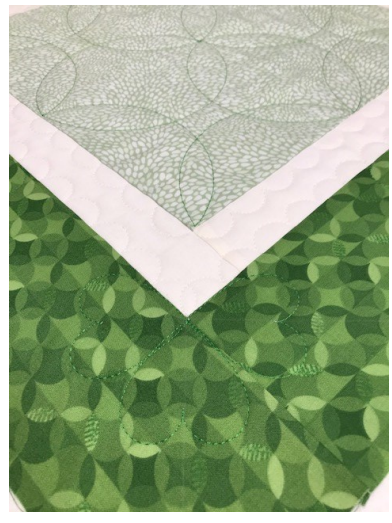

Westalee
DESIGN

Gold Accredited Teacher

Donelle McAdams

Email: sewbiz@indy.rr.com

Sew Steady
WWW.SEWSTEADY.COM
ELEVATE YOUR CREATIVITY

May not be reproduced in any format without permission.

ST. PATRICK'S DAY Table Runner

Description: This charming table runner is approximately 22" x 49". Elegant and easy to make, you will use this pattern for making other runners by changing the center block to fit the occasion. Learn TempLee Quilting using the Hearts Set of Templates. This will make a great item for your home or quick gift for a family member or friend.

Templates & Tools:

Sampler Set 1 Templates (6" Spiral, Scallop)

2" and 4" Hearts Templates, 12" Arc Template

Marking Tools & 8 pt. Cross Hair Square

1/2" Ruler Work Foot

12 1/2" Centering Ruler by Sew Biz

Bound to Fit Tool

Fabric:

A 3/8 yd **Cut:** 3 - 12 1/2" Squares

B 1/4 yd **Cut:** 2 - 12 1/2" x 2"

2 - 15 1/2" x 2" (may be adjusted)

2 - 39 1/2" x 2" (may be adjusted)

C 1 5/8 yd **Cut:** 1 - 12 1/2" Square (Cut this first)

2 - 4" x 41 3/4"

2 - 4" x 22"

1 - 25" x 52" Backing

E 1 - 12" Sq. TempLee
Fuse or Heat 'n
Bond Lite.

D 3/8 yd For Binding **Cut:** 4 - 2 1/2" by 40"

Batting:

1 pc.- 23" x 50"

Thread:

40 wt. 100% Polyester for quilting

60 wt. for construction

Needles:

#90 Top-Stitch Needle

#80 Universal Needle for
piecing



Sew Steady
WWW.SEWSTEADY.COM
ELEVATE YOUR CREATIVITY

Donelle McAdams

765-661-1458

sewbiz@indy.rr.com

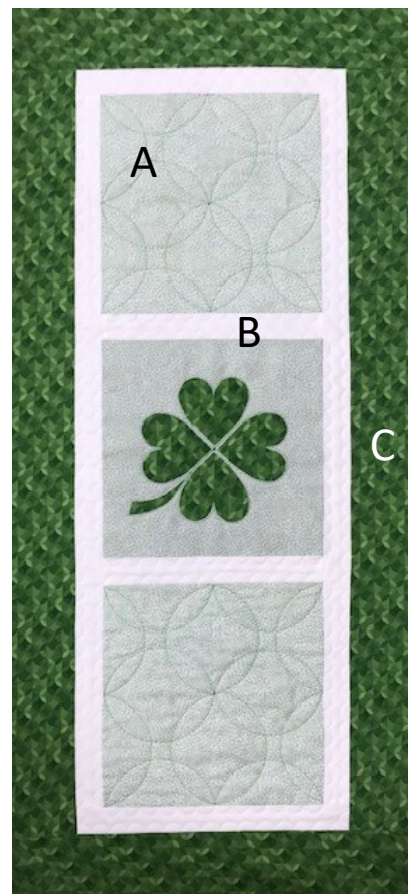

Construction of Table Runner

Use 1/4" seam allowance.

1. On the BACK of (1) of the A pieces (12 1/2" Square), CENTER the TempLee Fuse or Hent 'n Bond Lite. Fuse in place following product instructions. Let cool and then remove the paper.
2. Lay this piece on top of the RIGHT SIDE of the 12 1/2" square of Piece C.
3. With the iron, FUSE the two pieces together AROUND THE OUTER EDGE (only 3/4" from the outer edge of the square).
4. Using the (2) 2" x 12 1/2" Piece B fabrics, stitch as shown. Use a 1/4" seam allowance.
5. Remember not to PRESS into the CENTER Square more than 3/4". Press seams AWAY from the B (sashing) pieces.

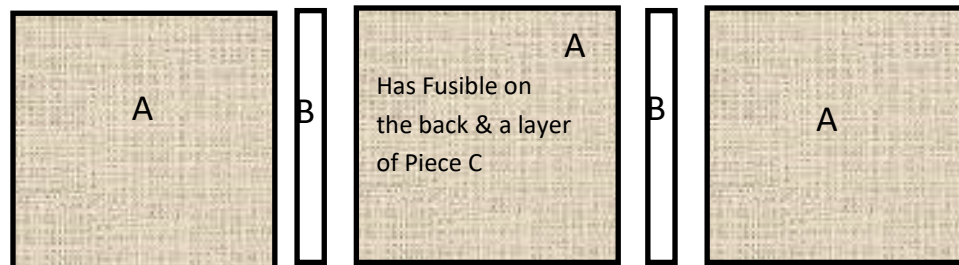

6. Stitch the (2) long Piece B 2" strips to the 2 long sides of the runner. Press seams to the sashing. Remember the Center block is not to be pressed inside of 3/4".
7. Stitch the (2) short Piece B 2" strips to the sides of the runner. Press seams to the sashing.

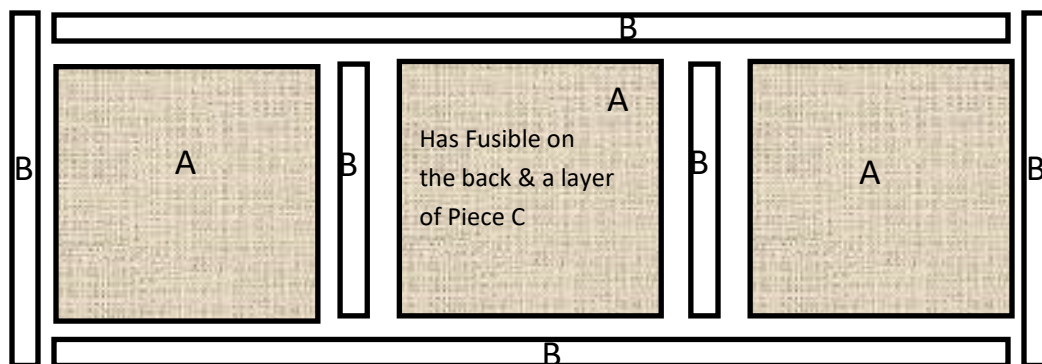

8. Measure the long sides. Cut to length and stitch the (2) long 4" wide Piece C border strips to the long sides of the runner. Press seam to the C border.
9. Measure the short sides. Cut to length and stitch the (2) short 4" wide Piece C border strips to the short sides of the runner. Press seam to the C border.

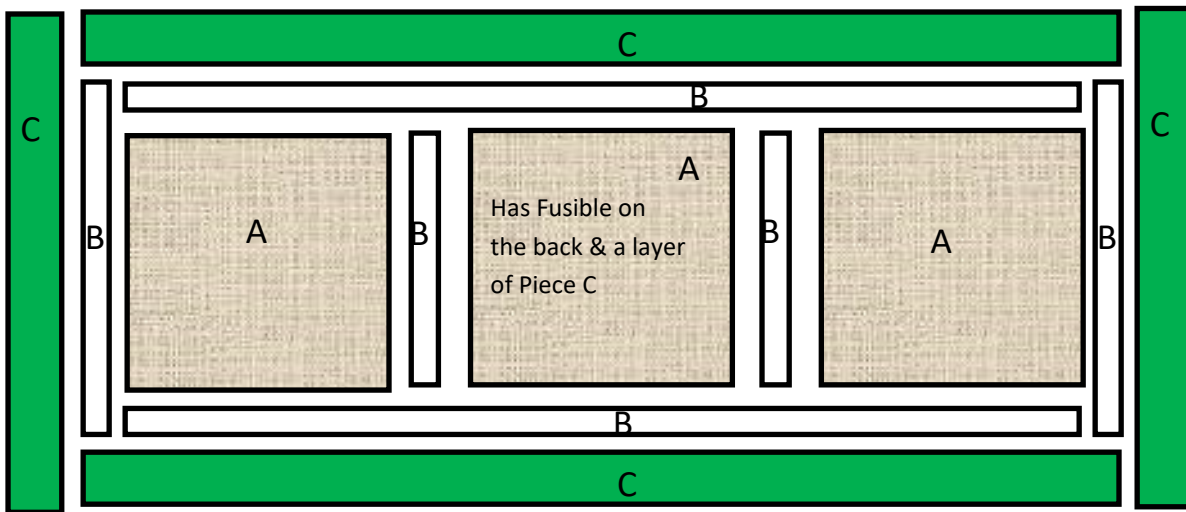

10. Layer the Backing, Batting and Runner to prepare the quilt sandwich. Baste as desired.

TempLee Quilting the Center Block

NOTE: Do not PRESS CENTER Block until it is completely finished.

11. Use the Centering Ruler to find the EXACT Center of the CENTER Block.

12. Use the Cross Hair Square to mark the **+** lines with an iron off marker.

13. Bring the bobbin thread up in the CENTER.

14. Position the 4" Heart Template as shown.

15. Stitch from the bottom of the heart to the top.

16. Flip the template side to side and stitch back to the CENTER.

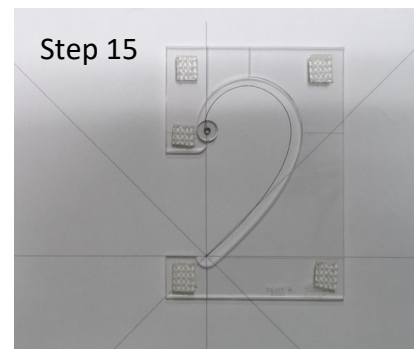
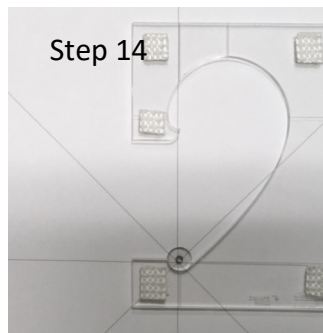

17. REPEAT on all 4 of the **+** lines.

18. Bring up the bobbin thread and SECURE threads.

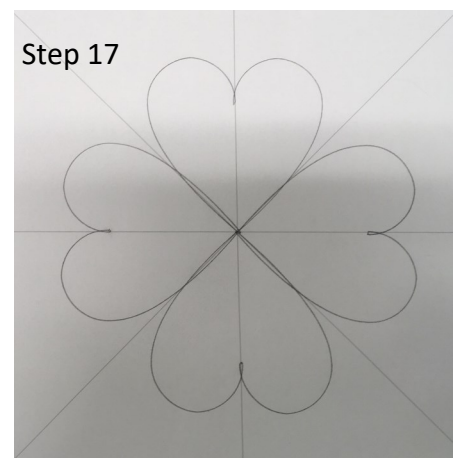
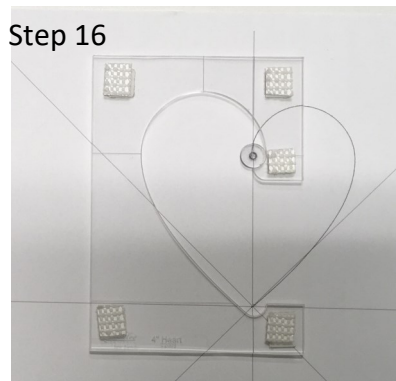

19. Measure 2" DOWN and 2 3/4" over from the CENTER vertical line and make a mark.

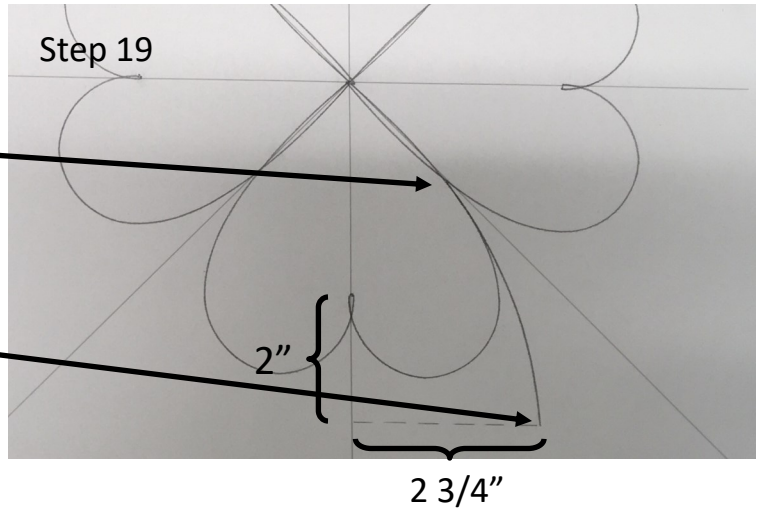

20. From where the bottom and right heart shapes meet, use the 12" Arc Template to stitch to the point marked in Step 19.

21. Use the straight side of the 12" Arc to stitch to the right 1" to form the bottom of the stem.

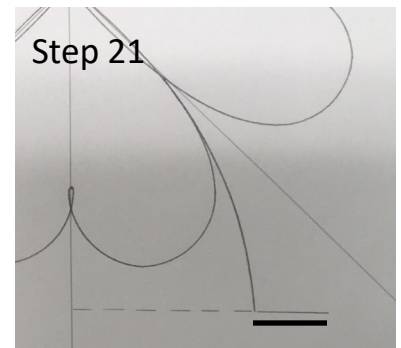

22. Position the 12" Arc Template as shown and use the Spacing Gauge to position the Template to complete the right side of the Shamrock Stem.

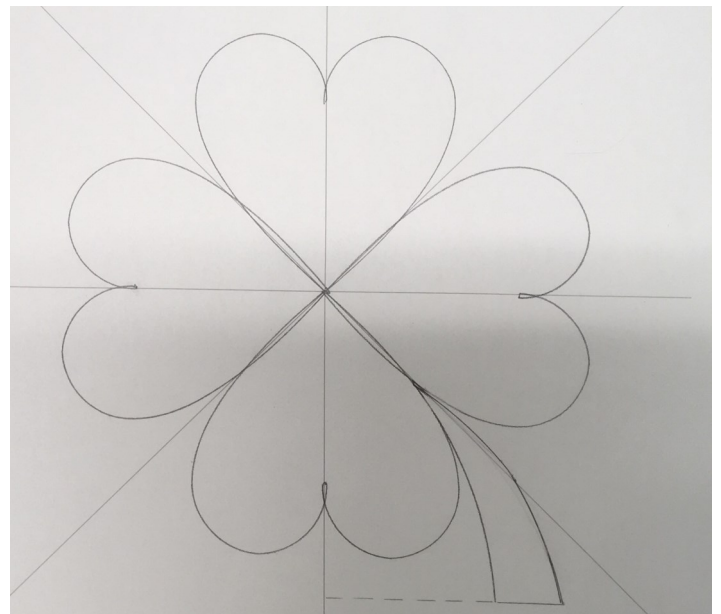
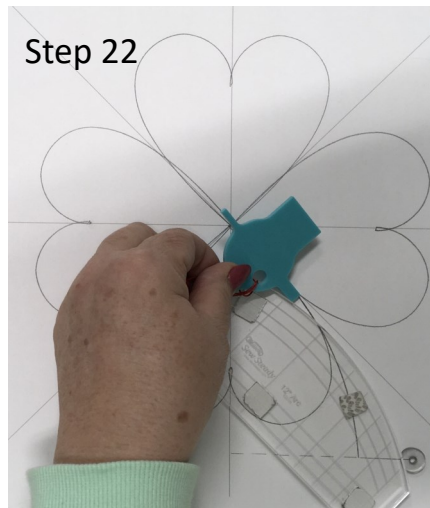

TempLee Quilting

23. Use small, sharp to the point, scissors or snips to cut out the hearts and stem. I recommend **4 3/4" Snip EZE Snips**.

24. Use a very pointed SEAM RIPPER to lift the top layer. Make a slice in the TOP LAYER of fabric backed with fusible.

25. Use the sharp scissors or snips to cut close to the stitching (~ 1/8"), to reveal the 'peeker' fabric. When you are completely satisfied, PRESS to fuse the entire block.

26. On the 2 side blocks, find the center and use an iron-off marker to mark of 4 equal sized squares inside the block.

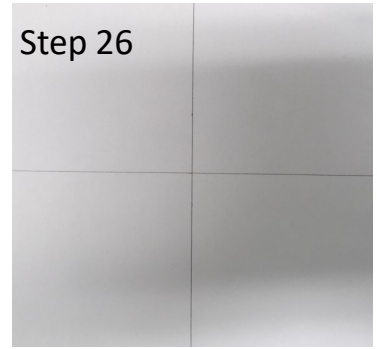

27. Bring the bobbin thread up in the CENTER. Use the 6" Spiral Template as shown.

28. Use the Spacing Gauge to allow 1/4" inside of the outer border. Stitch the ARC.

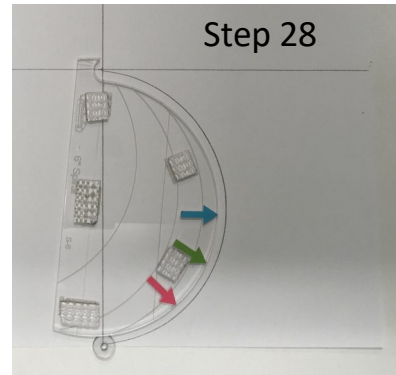
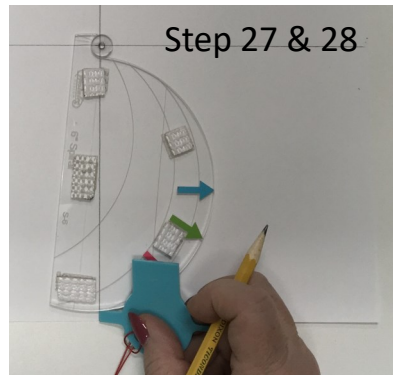

29. Rotate the 6" Spiral, use the Spacing Gauge to measure and continue around the square, returning to the center.

30. REPEAT in all 4 squares of the block.

31. REPEAT in the remaining block of the runner.

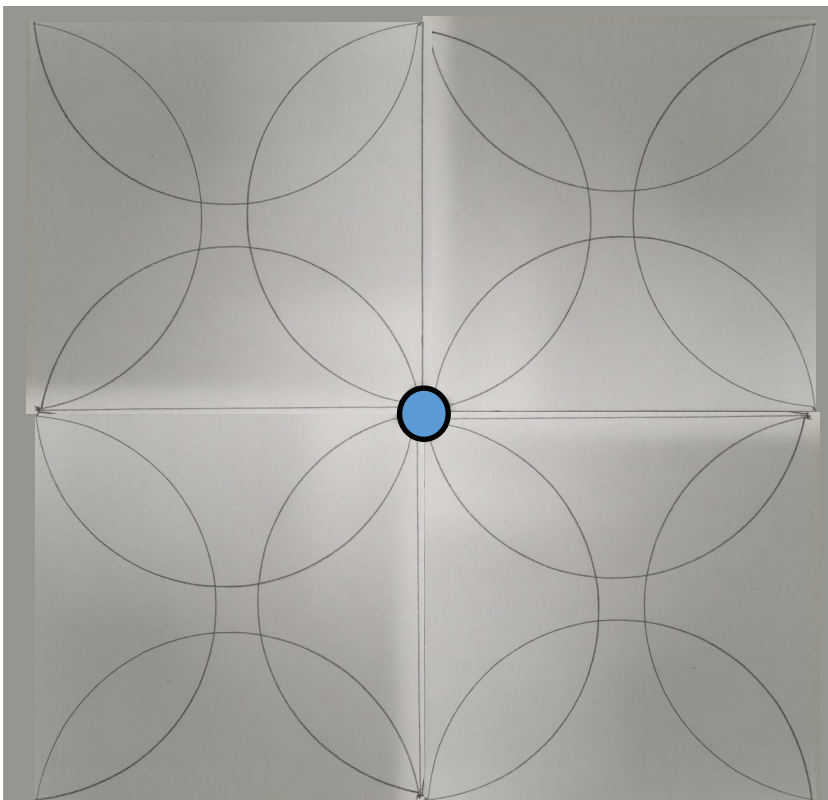
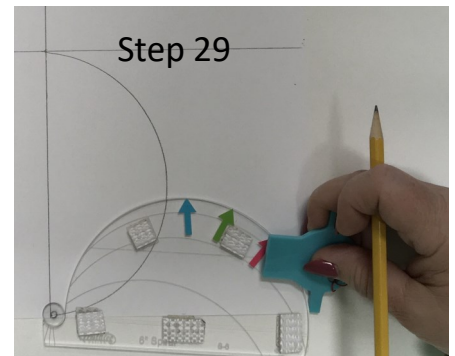

32. Use the Scallop Template around the outer edge of the blocks to FRAME each block with a scallop edge. REPEAT for all 3 Blocks.

33. The same pattern will be stitched around the outer edge of the Sashing Strips.

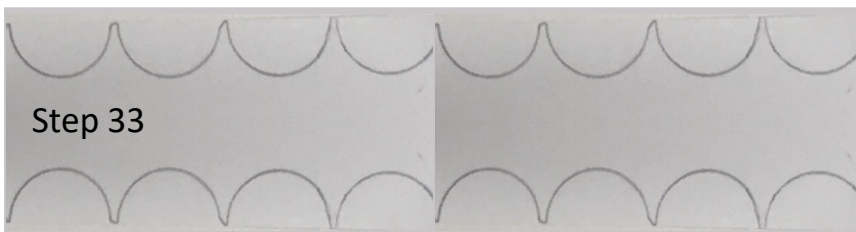
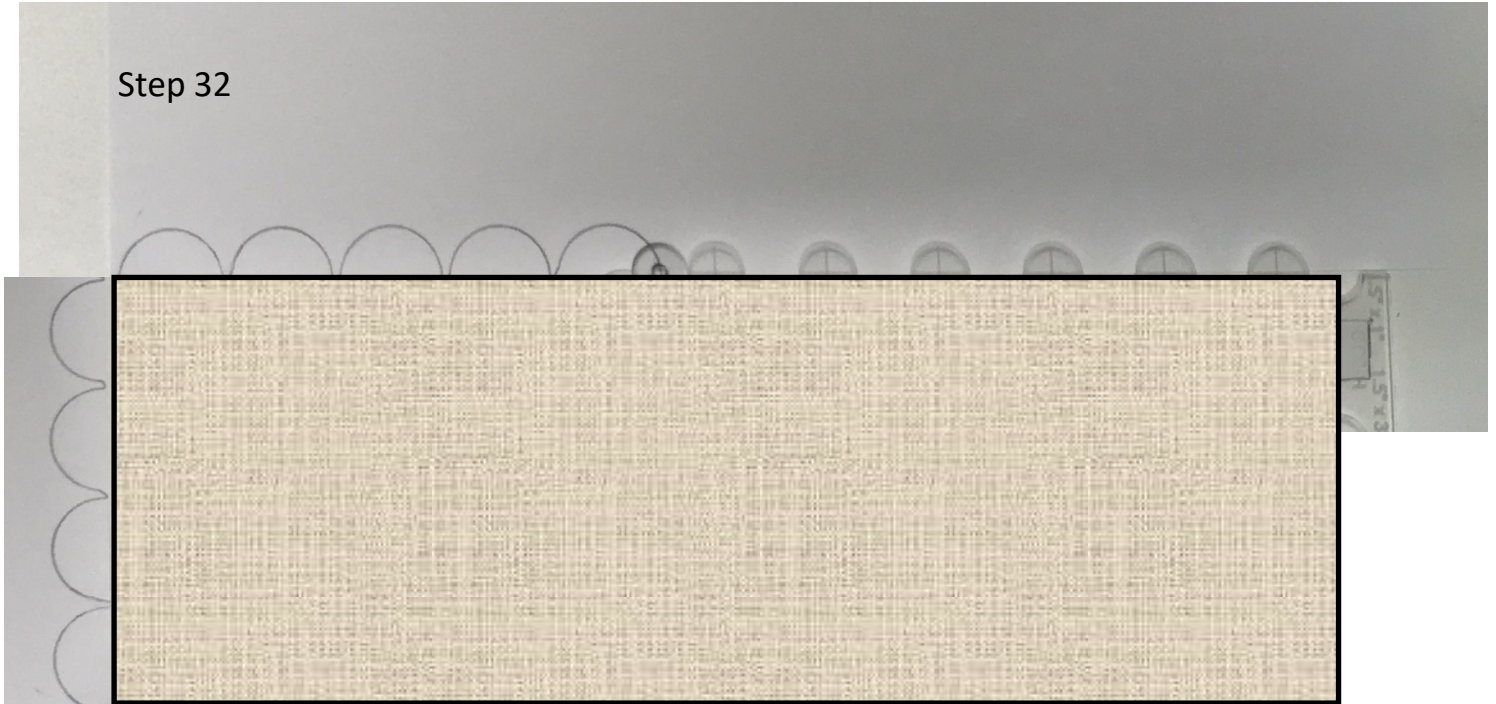

34. On each of the 4 corners, use the Cross Hair Square to mark as shown.

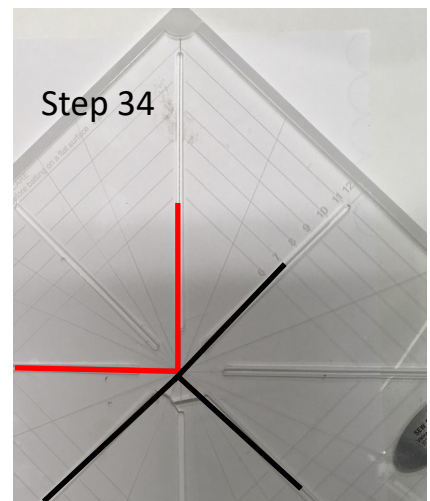
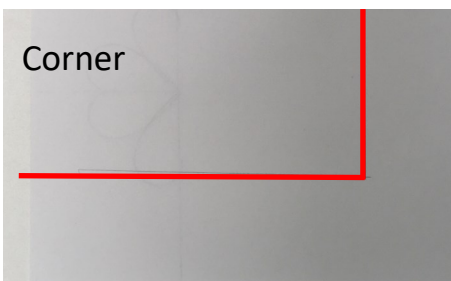

35. Use the 2" Heart Template and position as shown. Bring the bobbin thread up the corner of the outer border.



36. Stitch to the TOP of the heart.

37. Flip template and stitch back to the bottom of the heart.

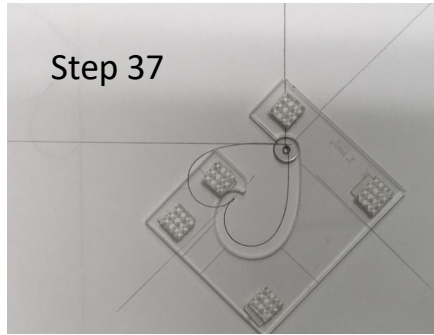
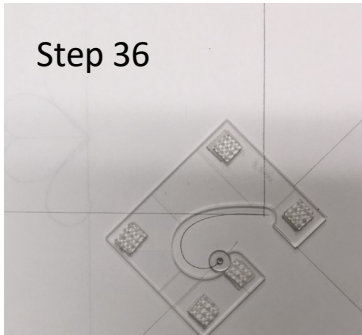

38. Repeat on the other 2 lines to create the 3 Hearts Design.

39. Repeat this design on all 4 corners of the runner.

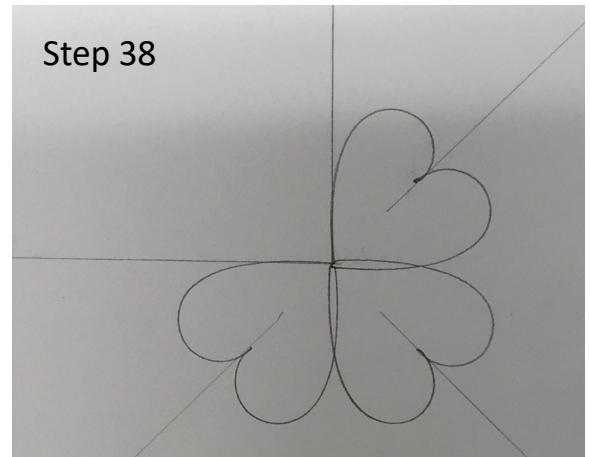

Marking the outer border for the Border Design

40. Mark the OUTER border as shown.

- ◆ CENTERS of the outer sides of the blocks. ●
- ◆ CENTERS of the sashing strips. ●

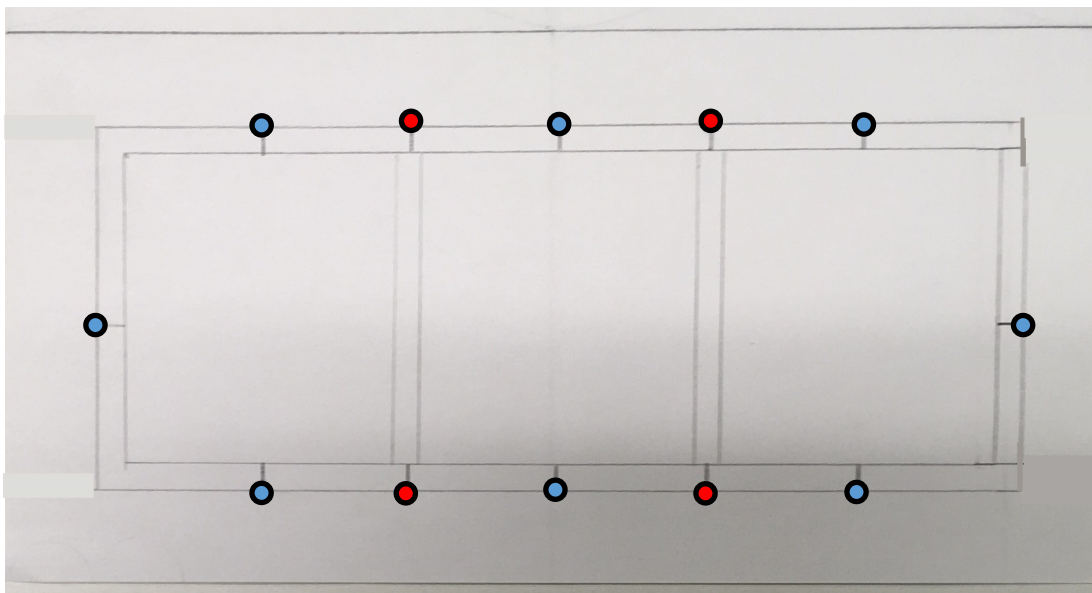

41. At each of the marks made in Step 40, use a straight edge to draw a line PERPENDICULAR to the border seam as shown.

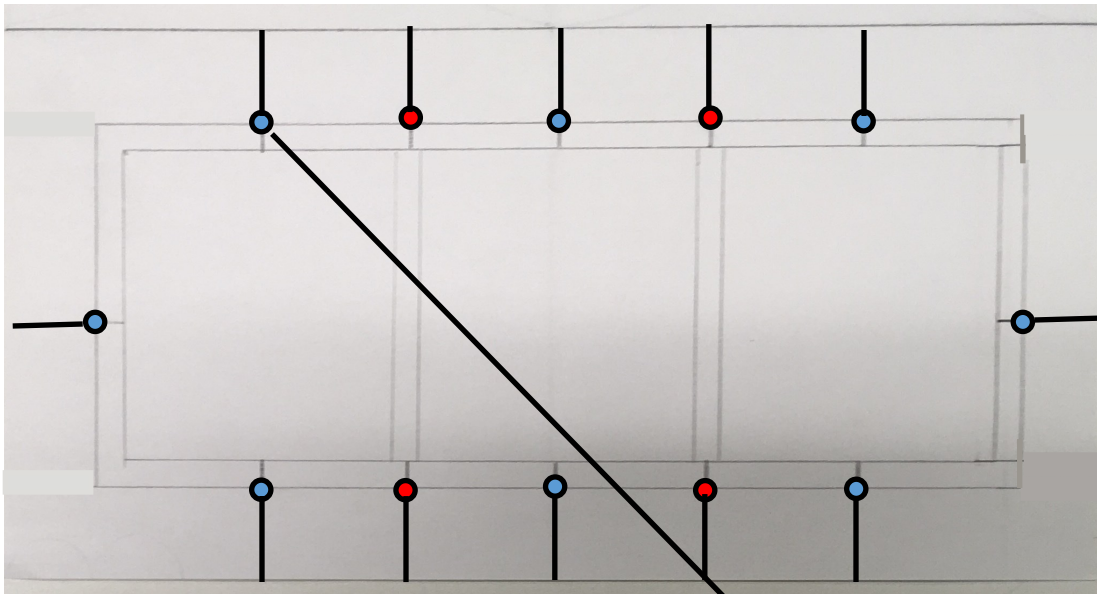

42. Position the 2" Heart Template as shown. Line up the etchings on the template (indicated by the dashed lines). This STARTING POINT is at the TOP of the heart template.

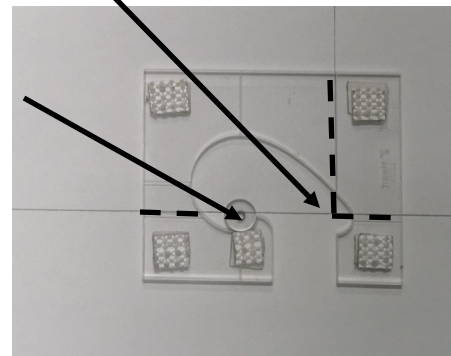

43. Bring up the bobbin thread. Stitch to the BOTTOM of the heart. Rotate the template as shown.

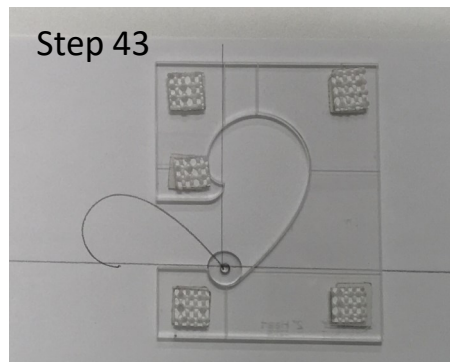

44. Stitch to the TOP of the heart template.

45. Flip the template and stitch back to the bottom.

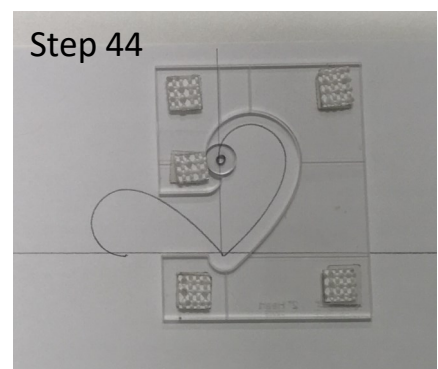
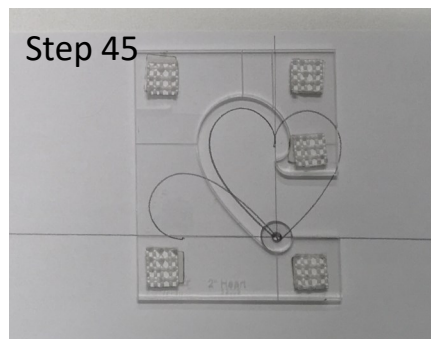

46. Rotate the template as shown and stitch. This is the completion of the design.

47. Stitch this design at all of the positions marked in Step 40.

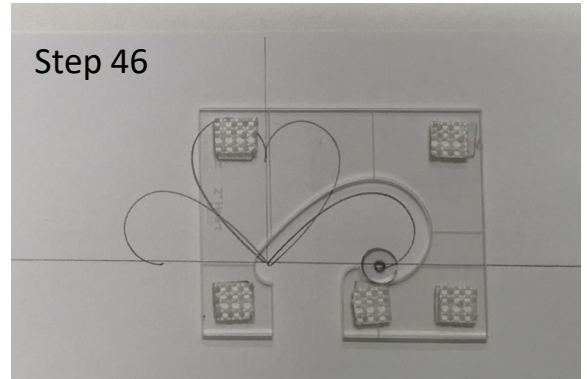
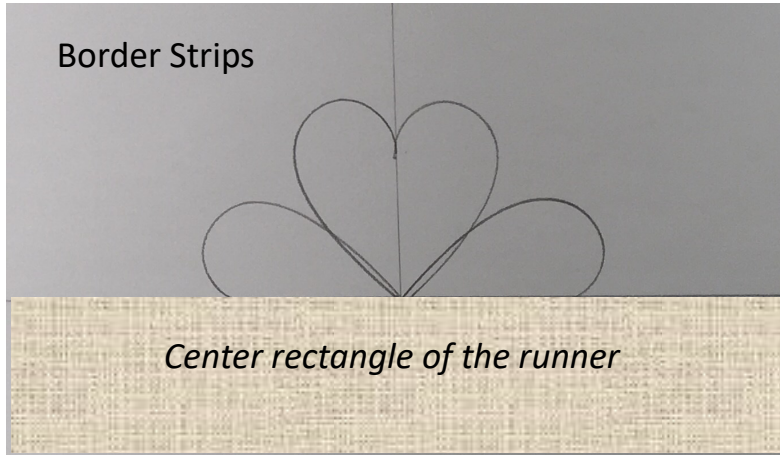

48. Square up runner and bind as desired.

NOTE: I used a tool that I designed - *Quick Easy Mitered Binding Tool* - to bring the back to the front, forming the binding. This tool is available at www.sewbizmarion.com



This Runner can be made for any season or occasion by changing the center block. Please feel free to add your own 'twist' to any of the designs used in the pattern. Here is an idea using the 2" & 4" Heart Template in another design for TempLee Quilting.

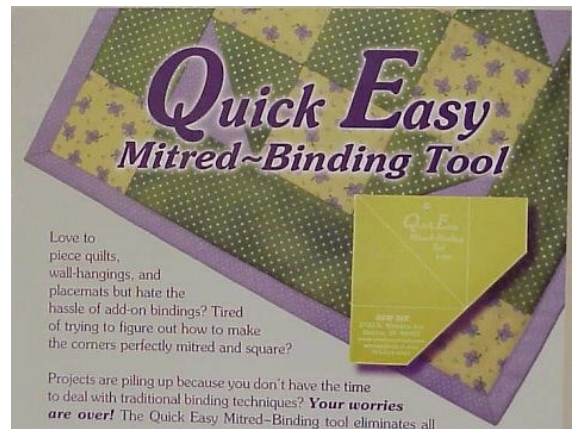
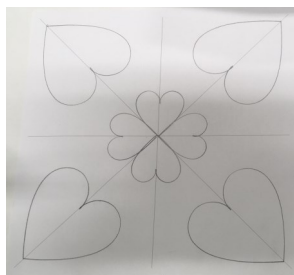

Donelle McAdams

Email: sewbiz@indy.rr.com



Gold Accredited

This pattern may not be reproduced in any format without permission.